

# Vents

Practical for fresh and healthy air

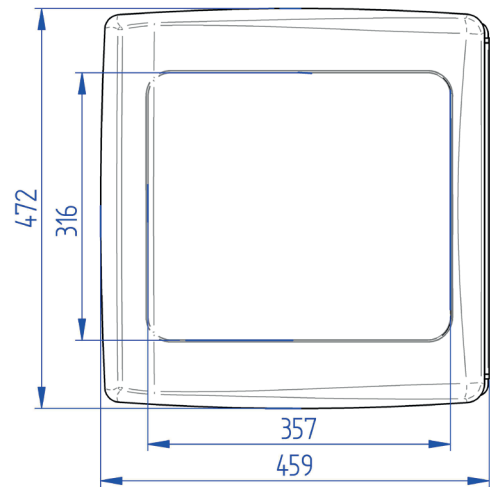
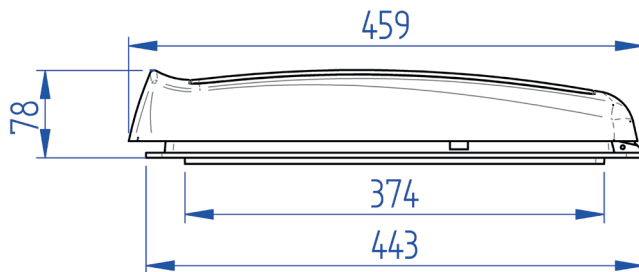

## FEATURES

- Easy to use
- Drill-free installation: clamping system
- Manual or motorised (12V)
- Various dome designs:
  - white = opaque
  - translucent = milk, frosted effect
- Retrofit ventilator kit
- Weight manual vent: 3 kg
- Weight motorised vent: 4.5 kg
- All materials are made of impact and weather-resistant plastics
- Mosquito screen on the outside of the vent to keep dirt and vermin out
- Security: in addition to 12 ventilation speeds, the Thule Vent has an energy-saving function, a boost function, and a safety mechanism to prevent excess voltage, incorrect connection and blockage



## INFO ROOF LIGHT

Aperture size	400 mm x 400 mm
Inner frame	458 mm x 426 mm
Height (closed)	78mm
Roof thickness	25mm - 60 mm
Max. opening angle	40°
Material dome white	Polypropylene
Material dome translucent	Polypropylene
Material inner frame	Polystyrene
Material curtain frame	ABS
Material outer frame	ASA
Free Air Flow	100 cm <sup>2</sup>

## INFO VENTILATOR

Consumption Thule Vent 12V	0.15 A - 2.50 A
Max. air flow	20 m <sup>3</sup> / min.
Diameter ventilator	300 mm

200004	Thule Vent - White	3 kg
200016	Thule Vent - Translucent	3 kg
200063	Thule Vent 12V - White	4.5 kg
200061	Thule Vent 12V - Translucent	4.5 kg
308226	Thule Additional Kit Roof 40-60mm	/
308229	Thule Retrofit Inner Frame	/
211001	Thule Ventilator 12V Kit	1.6 kg

The following products are compliant with UN ECE R10 regulations (certificate n° E1\*10R06/03\*9374\*03, issued on 25/03/82021:

- 200063 Thule Vent 12V White
- 200061 Thule Vent 12V Translucent
- 211001 Thule Ventilator 12V Kit

### USE OF VENTILATOR

- The ventilator is started by the soft switch S2. The middle LED light lights up and the ventilator starts in comfort mode, this is the lowest speed (extract).
- By pushing on the switch S1 (extract) or S3 (intake), the airflow can be adjusted in 6 steps.
  - MIN = 3,7 m³/min. (2 W - 0,15 A)
  - MAX = 20 m³/min. (34 W - 2,50 A)
- In order to save the battery, the speed drops from position 6 to the lowest position after one hour of use.
- It is possible to allow the ventilator to work for 5 minutes on the highest speed (boost). To do this push for 3 seconds on the button S1 (extraction) or S2 (intake). After 5 minutes the ventilator returns to its previous speed setting. See table.
- For reasons of security, the ventilator stops when the tension is too high (19,5V) or too low (11,1V) or when the fan is blocked. For trouble shooting see fig.

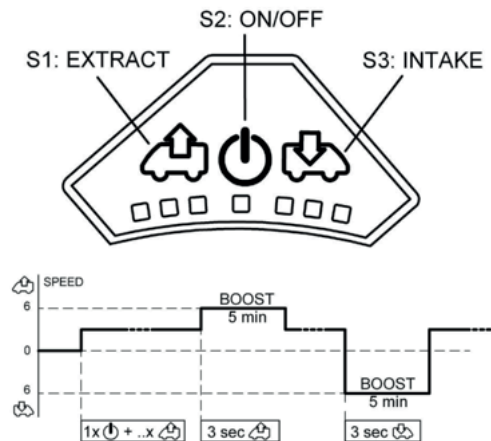

### VENTILATOR WITH SUPPLEMENTARY SWITCH

- If an external thermostat or proximity switch (with time-delay relay with normal closed contact) is connected, you can turn the ventilator on or off with the switch S2 and choose the direction and speed with the switch S1 or S3. The ventilator will only work when the external thermostat or proximity switch is activated.

- Remark: If you will be away from the vehicle for a long period we suggest that you set the fan at a low speed level when using the thermostat. This will reduce the possibility of draining the battery.

PUSH BUTTONS	LIGHTS	SPEED	Ampère	Watt
	■ ■ ■ ■ ■ ■ ■ ■	0	0,2 mA	2,4 mW
1x ⏻	■ ■ ■ ■ ■ ■ ■ ■	1Ω	0,15 A	2 W
1x ⏻ + 1x ⏪	■ ■ ■ ■ ■ ■ ■ ■	2Ω	0,35 A	5 W
1x ⏻ + 2x ⏪	■ ■ ■ ■ ■ ■ ■ ■	3Ω	0,65 A	9 W
1x ⏻ + 3x ⏪	■ ■ ■ ■ ■ ■ ■ ■	4Ω	1,20 A	17 W
1x ⏻ + 4x ⏪	■ ■ ■ ■ ■ ■ ■ ■	5Ω	1,70 A	24 W
1x ⏻ + 5x ⏪	■ ■ ■ ■ ■ ■ ■ ■	6Ω	2,50 A	34 W
1x ⏻ + 5x ⏪ + 1x ⏪	■ ■ ■ ■ ■ ■ ■ ■	5Ω		
1x ⏻ + 5x ⏪ + 2x ⏪	■ ■ ■ ■ ■ ■ ■ ■	4Ω		
... ..				
1x ⏻	■ ■ ■ ■ ■ ■ ■ ■	0	0,2 mA	2,4 mW

### MAINTENANCE

The ventilator grid can be removed for cleaning, as well as the mosquito screens. Always shut down the current with the main switch.

### TRANSPORTING THE CARAVAN WITH A THULE VENT







The roof light is only waterproof in the direction of the traffic. When transporting the caravan in the opposite direction, or when the back of the caravan is up, ensure the dome is watertight by using the 'Lock-unlock' (not supplied on a ventilator version) or by using something that ensures that the dome remains closed when being transported.





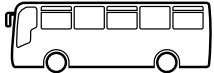



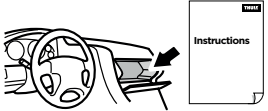





PUSH BUTTONS	LIGHTS	SPEED	Ampère	Watt
	■ ■ ■ ■ ■ ■ ■ ■	0	0,2 mA	2,4 mW
1x ⏻	■ ■ ■ ■ ■ ■ ■ ■	1Ω	0,15 A	2 W
1x ⏻ + 1x ⏪	■ ■ ■ ■ ■ ■ ■ ■	0	15 mA	0,2 W
1x ⏻ + 2x ⏪	■ ■ ■ ■ ■ ■ ■ ■	1Ω	0,15 A	2 W
1x ⏻ + 3x ⏪	■ ■ ■ ■ ■ ■ ■ ■	2Ω	0,30 A	5 W
1x ⏻ + 4x ⏪	■ ■ ■ ■ ■ ■ ■ ■	3Ω	0,50 A	9 W
... ..				

### TROUBLE SHOOTING

FLASHING LED's	PROBLEM
■ ■ ■ ■ ■ ■ ■ ■	or Tension < 11,1 V or Tension > 19,5V
■ ■ ■ ■ ■ ■ ■ ■	Motor blocked
■ ■ ■ ■ ■ ■ ■ ■	Motor not connected

**i** **UNIFORM PROVISIONS CONFORMITY ROOFLIGHTS**

Transparent	Translucent White			
✗	✗	M1		✗ not compliant
✗		M1		✓ compliant
✗	✗	M2 M3	 9+	n.a. not applicable
✗	✓	N		 mounting restriction
✗	✓	O		

		TRANSPARENT		TRANSLUCENT		WHITE	
REGULATION	VEHICLE CATEGORY	MANUAL	VENTILATOR	MANUAL	VENTILATOR	MANUAL	VENTILATOR
UN R.43	M 	✗	✗	n.a.	n.a.	n.a.	n.a.
	N 						
	O 						
UN R.26	M1  			✓	✓	✓	✓
UN R.10	M 			n.a.	✓	n.a.	✓
	N 						
	O 						
UN R.21	M1  						
UN R.118	M3 			✗	✗	✗	✗

## 1 UN R.43 (SAFETY GLAZING MATERIALS)

VEHICLE CATEGORY	TRANSPARENT		TRANSLUCENT		WHITE	
	Manual	Ventilator	Manual	Ventilator	Manual	Ventilator
M, N, O	✗	✗	n.a.	n.a.	n.a.	n.a.

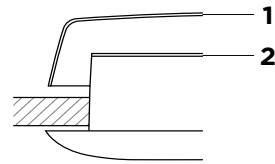
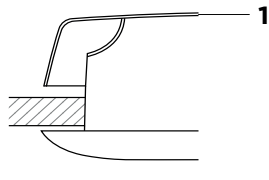

## 2 UN R.26 (EXTERNAL PROJECTIONS)





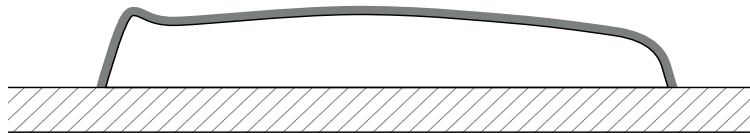

VEHICLE CATEGORY	TRANSPARENT		TRANSLUCENT		WHITE	
	Manual	Ventilator	Manual	Ventilator	Manual	Ventilator
M <sub>1</sub>			✓	✓	✓	✓



**3 UN R.10 (ELECTROMAGNETIC COMPATIBILITY)** CE 

VEHICLE CATEGORY	TRANSPARENT		TRANSLUCENT		WHITE	
	Manual	Ventilator	Manual	Ventilator	Manual	Ventilator
L, M, N, O			n.a.	✓	n.a.	✓

**4 UN R.21 (INTERIOR FITTINGS)**

VEHICLE CATEGORY	TRANSPARENT		TRANSLUCENT		WHITE	
	Manual	Ventilator	Manual	Ventilator	Manual	Ventilator
M <sub>1</sub>						

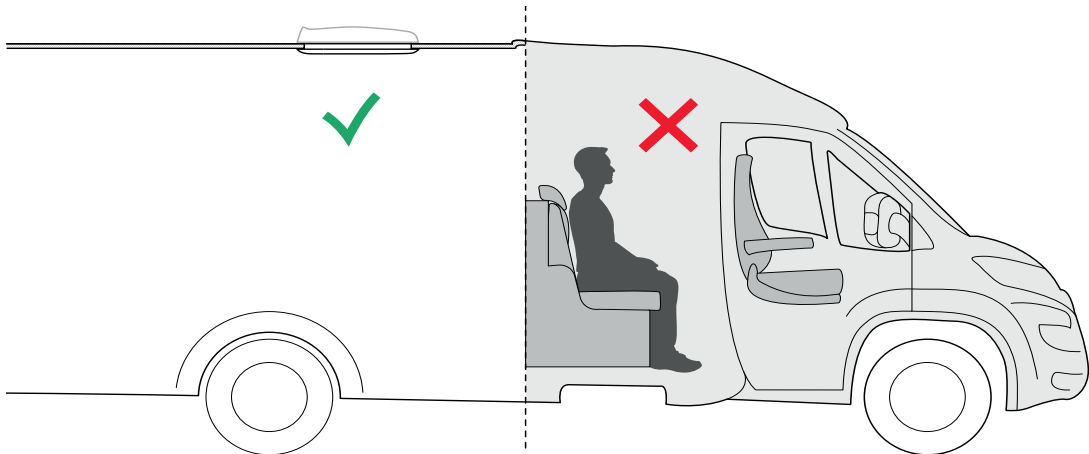

## 5 UN R.118 (BURNING BEHAVIOR OF INTERIOR MATERIALS)

VEHICLE CATEGORY	TRANSPARENT		TRANSLUCENT		WHITE	
	Manual	Ventilator	Manual	Ventilator	Manual	Ventilator
M <sub>3</sub>			×	×	×	×

